

Using Grid Related Cluster Schedule Resemblance for Energy Rescheduling

Goals and Concepts for Rescheduling of Clusters in Decentralized Energy Systems

Astrid Nieße¹ and Michael Sonnenschein²

¹*OFFIS - Institute for Information Technology, Escherweg 2, 26121 Oldenburg, Germany*

²*Department for Computer Science, University of Oldenburg, 26111 Oldenburg, Germany*
astrid.niesse@offis.de, michael.sonnenschein@informatik.uni-oldenburg.de

Keywords: Active Distribution Grids; Energy Scheduling; Virtual Power Plants; Graph Theory

Abstract: Transforming the electric power system to incorporating a considerably increased share of renewable distributed generation implicates new challenges for the control of the system. To overcome the known shortcomings of centralized control, e.g. regarding scalability and robustness, a decentralized, self-organized system of agents for generators, loads and storages is widely discussed. We focus on a dynamic aggregation of these units to participate on current and future energy markets for both active power and new ancillary services products. With these units participating in system services, rescheduling of units within clusters becomes a more complex task that should reflect grid usage properties. In this work, we develop grid related cluster schedule resemblance as a metric to analyze the grid usage changes using graph theory. This metric can be used to compare different rescheduling options regarding grid usage for both dynamic clusters of distributed energy resources and for rescheduling of static clusters like virtual power plants. An example is used to show that this metric can be used as a separate optimization target for the multi-criteria optimization problem of cluster rescheduling.

1 INTRODUCTION

Transforming the electric power system to incorporating a considerably increased share of renewable distributed generation implicates new challenges for the control of the system: The control method has to cope with many individually configured, distributed, small generation units and with fluctuation in their feed-in. These units can form clusters to participate in energy markets - a concept well known as virtual power plants (VPP) as presented by Bitsch, Feldmann and Aumayr (2002) or Abarrategui, Marti and Gonzalez (2009).

Traditional energy management relies on centralized systems to control a static set of conventional power plants. The concept of VPPs mimics this approach by aggregating small units to centrally controlled static clusters that are able to cope with the market barriers on nowadays energy markets. To overcome the known shortcomings of centralized control, e.g. regarding scalability and robustness, a decentralized, self-organized system of agents for small active units (generators, loads, storages) has been proposed for several years (Kok et al., 2005), (Dimeas and Hatziar-

gyriou, 2007), (Jansen et al., 2008), (Kok, 2010), (Ramchurn et al., 2012). Besides this control concept designed for active power product delivery, distributed units are needed to fulfill grid-stabilizing tasks to effectively substitute fossil power plants not only from an energy market point of view, but also reflecting grid operation constraints. In such a scenario, distributed energy components (both generating and consuming power) form clusters to participate on energy markets and to fulfill grid-stabilizing tasks with different requirements regarding the location of the units in the power grid.

Market design, cluster formation for distributed units and the task of continuous energy scheduling are the main tasks that have to reflect the requirements and effects of using distributed units for grid stabilization purposes. This paper deals with continuous energy rescheduling for clusters of small distributed generation units, consumers and electrical storage as described by Nieße, Lehnhoff, Tröschel, Uslar, Wissing, and Appelrath (2012). A metric is introduced to include grid aspects in the multi-criteria optimization problem of energy cluster rescheduling.

The rest of this paper is structured as follows: First,

the task of continuous cluster energy scheduling is described, giving an insight in the optimization criteria of this task and pointing out, why grid topology matters. We then elaborate on related work regarding rescheduling in the distribution grid and graph based modeling of power grids. Then, a formal representation of the power grid as a weighted graph is proposed, including a weighting function and a concept for neighborhood of units within a power grid. The fifth section shows, how this concept can be used to characterize the changed grid usage profile of a cluster schedule consisting of individual units' schedules. Finally we point out, how these characteristics of a cluster schedule can be used for optimized election of a new cluster schedule.

2 CONTINUOUS ENERGY SCHEDULING

2.1 Energy Products and Schedules

In our concept, small distributed generation units and controllable loads form clusters and bid for products on energy markets, e.g. on nowadays day-ahead markets. The scheduling is done for a time span T (e.g. 24 hours) as set of time intervals $t^{(i)}$ (e.g. with a length of 1 minute). For the rest of this paper indices given in brackets and superscript form relate to the respective time intervals, whereas all other indices are subscripted.

A cluster C is defined as the set of aggregated units u_i :

$$C = \{u_i, \dots, u_n\} \quad (1)$$

A product p is defined by the amount of energy to be delivered $e_p^{(i)}$ for each time interval $t^{(i)}$ as follows (with $T_{pr}^{(p)}$ as set of all time intervals that the product p spans):

$$p : T_{pr}^{(p)} \rightarrow \mathbb{R}, p(t^{(i)}) = e_p^{(i)} \quad (2)$$

$$T_{pr}^{(p)} \subset T, T_{pr}^{(p)} = \{t^{(i)}, \dots, t^{(i_{max})}\} \quad (3)$$

To realize a product, operation schedules os for each cluster unit u are generated, reflecting the amount of energy delivered or used by a unit ($e_u^{(i)}$) and the costs for this amount of energy ($c_u^{(i)}$) for each time interval $t^{(i)}$ (e.g. each minute of a day) for this specific unit:

$$os_u : T \rightarrow \mathbb{R}^2, os_u(t^{(i)}) = (e_u^{(i)}, c_u^{(i)}) \quad (4)$$

The set of operation schedules of all units u that are part of a cluster C is defined as:

$$OS = \{os_{u_i} | u_i \in C\} \quad (5)$$

A cluster schedule cs assigns an operation schedule os_{u_i} to each unit u_i within the cluster:

$$cs : U \rightarrow OS, cs(u_i) = os_{u_i} \quad (6)$$

Following this cluster schedule, the product is fulfilled, when the sum of power contributions by all cluster units meets the product definition in each time interval.

2.2 Incidents and the Need for Rescheduling

Between market matching and product delivery though, several incidents may render the operation schedules infeasible. We distinguish three types of incidents:

- **Changed reactive power behavior:** When small and distributed energy units are used for grid-stabilizing issues, e.g. reactive power delivery, hard real-time constraints have to be fulfilled. Requirements like this e.g. for a fixed $\cos \phi$ are defined in national grid codes (e.g. (VDE, 2011) for generating units in the low voltage level). In our concept, we define such requirements in a more dynamic fashion depending on the current grid state as described by Gandor, Blank and Lehnhoff (2012). A changed reactive power behavior may lead to a changed active power profile. Therefore this incident type can affect the active power contribution without notification, although an increased risk for such incidents might be known in advance from the unit's reactive power behavior configuration.
- **Changed active power behavior:** Prognosis faults regarding active power feed-in behavior are typical for fluctuating renewable energy resources. Prognosis quality rises with decreasing time to delivery. The same holds for prognoses regarding the behavior of controllable and non-controllable loads.
- **Unit failure:** With a high share of distributed and small units in such a system, unit failure with preliminary notification (e.g. for maintenance) or without (e.g. breakdown) has to be considered.

Incidents of these types may render the delivery of the power product infeasible, thus raising the need for rescheduling, i.e. generating new and valid operation schedules for some of the units within the cluster.

2.3 Requirements and Goals for Rescheduling

Generating a new cluster schedule has to reflect several requirements:

First, the power product has to be delivered as contracted at the market. Although an exact delivery may not be possible, the new cluster schedule should minimize the deviation in active power delivery. It should not be possible to trade off product delivery costs against current balancing energy costs that have to be paid in case of prognosis deviations. The German energy market e.g. prevents such a tradeoff by defining a lower margin for balancing energy costs by the current power price on energy markets (Bundesnetzagentur, 2012).

Second, the additional costs that emerge from reconfiguring the units within the cluster should be minimized, i.e. by minimizing the sum of reconfiguration costs and the difference between costs for old and new schedule execution. This requirement may be weighed against the robustness of the new cluster schedule: If rescheduling comes with additional costs, the new schedule should be tolerant to additional incidents.

When a product is contracted at the market, the resulting usage of the power grid has to be tested for admissibility. Abarrategui, Marti and Gonzalez (2009) perform a check for admissibility after market matching, whereas Khattabi, Hübner, Kießling and Braun (2012) propose a check before market matching to adapt grid charges accordingly. In both concepts, several grid calculations and load flow analyses have to be performed. We expect, that for continuous energy scheduling, these calculations cannot be performed in any case for reasons of time constraints and lack of (dynamic) information on the grid state. Nevertheless, the reconfiguration of units may lead to critical grid states regarding utilization and remaining transmission capacity of lines and transformers. Critical grid states have been a topic in transmission grids for a long time, and with more and more distributed generation this has to be reflected for the distribution grid as well. Demand side management additionally may aggravate this as simultaneity factors may change dramatically as analyzed by Gwisdorf, Stepanescu and Rehtanz (2010).

Therefore we propose to reflect the grid when setting up a new schedule and to maximize the resemblance of the schedules regarding the utilization of the grid, thus minimizing the risk for critical grid states, when admissibility checks cannot be performed in time.

The goals for rescheduling can be summarized as follows:

- Deliver active power product as contracted,
- minimize additional costs emerging from rescheduling and reconfiguration of units,

- maximize robustness of new cluster schedule and
- minimize changes in the usage of the power grid.

In the following sections a concept to reflect the power grid related optimization target for continuous energy scheduling is presented. As can be seen from the goals above, this is part of a multi-criteria optimization problem. We aim to define the grid related optimization target as a separate target that does not have dependencies to other targets, especially regarding the number of reconfigurations (i.e. the number of units that need to be adapted in their operating behavior) needed: Weighting of the optimization targets might change over time, as – when there is still enough time until product delivery – cost optimization regarding the units might override robustness. When the grid state is considered critical though, we might prioritize these aspects over costs. Therefore we want to decouple the grid related metric from the other optimization targets.

3 RELATED WORK

This section deals with related work for rescheduling of units in the distribution grid and - as a means to achieve this - for analyzing the power grid using approaches from graph theory. An overview on related work regarding dynamic aggregation of energy units in the distribution grid is given by Nieße et al. (2012). In contrast to the transmission grid, where a continuous measurement allows to detect violations of grid operational constraints, no such infrastructure is installed in the distribution grid, especially on the low voltage level. Moreover, due to the large amount of units in the distribution grid, the identification of the most efficient unit to avoid a critical grid state cannot be deduced manually. Additionally, the underlying optimization problem of identifying the most efficient mitigation actions is challenging due to the non-linearity and non-differentiability of the underlying power flow equations as shown by Handschin, Rehtanz, Wedde, Krause and Lehnhoff (2008). Therefore, state-of-the-art control systems on the transmission level cannot be transferred directly to the lower voltage levels due to (a) lack of real-time information and (b) enlarged complexity of the redispatch problem.

In recent years, a lot of work has been done to develop control schemes appropriate to the distribution grid structure that overcome these problems like e.g. the work done by Krause and Lehnhoff (2012). A generalized static state estimation method is presented that is valid for power grids with missing input data. Neusel-Lange, Oerter and Zdrallek (2012) present an

approach for low voltage state identification and control handling the problem of missing data as well - the state estimation and control algorithm presented adds prediction of loads and feed-in for units lacking appropriate measurements. An established algorithm for power flow can thus handle real-time data and - if these are unachievable - predicted values (Neusel-Lange et al., 2012). These methods build on real-time information on the grid state, adding up substitute values for missing data.

For the approach presented in this work, we try to choose rescheduling options without real-time information for two reasons: First, as Blank, Gerwinn and Krause (2011) could show, identifying the most efficient redispatch from the huge amount of possible dispatch options is in itself a complex task. It is not yet clear how this approach could be integrated directly in a multi criteria problem covering other constraints like robustness and costs. Second, our concept is integrated in a market-based concept for active power products from dynamic clusters of distributed energy units. With the underlying process, a grid admissibility check is performed after market matching. We build on the results of that check and try to identify schedules that resemble the initial schedules regarding the grid usage using a graph-based approach.

The work of Barabasi and Albert (1999) and Albert, Jeong and Barabasi (2000) regarding the structural analysis of complex networks using graph theory has gained wide attention in the vulnerability analysis of power grids on the transmission level (Albert et al., 2004), (Holmgren, 2006), (Hines et al., 2010), (Schneider et al., 2011), (Chopade and Bikdash, 2011), (Wang et al., 2012). The transmission grid is transferred to a graph representation with the generators and loads as nodes in the graph and different concepts for generating the edges. Whereas Holmgren (2006) and Chopade and Bikdash (2011) generate the links as found in the grid topology, Hines and Blumsack (2010) and Wang (2012) connect nodes using the electrical distance of nodes to better reflect the engineering characteristics of the grid within the graph structure by choosing a threshold to distinguish connected from unconnected nodes that yields the known number of links (i.e. busses in the power grid). The latter approach showed good results for the vulnerability analysis of power grids using structural metrics like cluster coefficients or degree distribution. Dynamic effects in the transmission grids have been analyzed by Kinney, Crucitti, Albert and Latora (2005) for cascading failure analysis. They added weights to the edges of a node representing the efficiency of a line, with an efficiency of 0 prohibiting paths using that line and 1 meaning full usage of that

line is possible. The efficiency concept and its transfer to shortest path detection is discussed in detail in section 4.2.

Nguyen, Kling and Ribeiro (2011) solved a distributed control task in the power distribution grid using the graph representation as described in Nguyen, Kling and Myrzik (2010). The power distribution grid is represented using a graph with the edges representing the lines in the grid. Using this representation, an optimal power flow problem is solved in a distribution grid scenario. Whereas the structural vulnerability analysis has no need for generating a weighted graph, in this study on the dynamic usage of the grid weights are added to the edges reflecting the currently measured power flows. So for this approach, detailed system knowledge including both static and dynamic data is required.

4 REFLECTING THE GRID TOPOLOGY

As pointed out in section 3, power grids have been modeled as graphs for several applications by assigning a graph node to generating and power consuming units to model the grid connection node. In this section we apply and extend this concept in such a way, that it can be used for rescheduling of energy clusters with the optimization goal of identifying a schedule that leads to a similar grid usage as the original schedule. First, we pinpoint some design decisions for modeling the power grid as a graph. After that, a weighting function for edges in this graph is developed, that is needed to interrelate a change in the schedule to a change in the usage of the power grid. Using this extended model, the changed grid characteristics of a new schedule are defined in section 5.

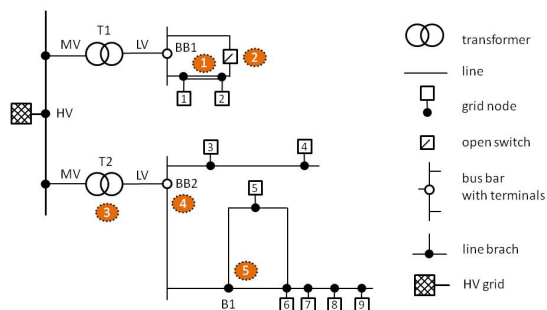

Figure 1: Simple example grid.

The power grid is transformed to an undirected graph $G = (V, E)$ with $V = \{v_1, \dots, v_n\}$ representing the vertices (the grid connection nodes with the generating and consuming units annotated to that node) and $E = \{e_1, \dots, e_n\}$ representing the edges between this nodes, i.e. the lines of the power grid. A unit u_i is assigned to a node v_j by the grid node assignment gn :

$$gn : U \rightarrow V, gn(u_i) = v_j \quad (7)$$

A simplified example of a medium voltage level grid is shown in figure 1. The following design decisions were chosen to generate the graph from this matrix (enumeration refers to labeled number in figure 1):

1. **Multiple lines between nodes:** No multiple edges are modeled. The edge between nodes 1 and 2 for example, probably strengthened by adding a parallel line, is modeled as a simple edge.
2. **Open switches:** Lines that are electrically disconnected by open switches are not modeled.
3. **Voltage level transitions:** Transformers are modeled as separate nodes in the graph.
4. **Bus bars:** Bus bars are modeled as nodes that may be connected to several nodes in the graph. Thus, the degree of node BB2 is $deg(BB2) = 3$, whereas BB1 has $deg(BB1) = 2$, as no node will be modeled between BB1 and the open switch (see figure 1).
5. **Line branching:** Line branching is modeled as separate node. Branch B1 has a degree $deg(B1) = 3$.

As a consequence, we distinguish three types of nodes that form the set V: Transformer nodes (set TN), bus bar nodes (set BB) and normal grid nodes (set GN).

$$V = TN \cup BB \cup GN \quad (8)$$

The artificial line branching nodes inserted in the graph are defined as normal grid nodes.

4.1 Weighting Function

The weights added to an edge in the resulting graph should allow to reflect the change of voltage levels in paths to prevent schedules with compensation strategies in completely different parts of the grid. In figure 2 this is illustrated with different paths within the graph derived from the example grid in figure 1. We take a closer look at $path_{1,3}$ and $path_{3,9}$. Both paths contain six edges. If only path length is considered, the neighborhood relation between the nodes is identical. In power systems

though, changes between voltage levels include conversion losses and - different from social networks or other complex systems that may be represented using graph theoretical concepts - distance (edge length) matters. Using the electrical distance for the weighting function has been done by Nguyen, Kling and Ribeiro (Nguyen et al., 2011). We propose a different approach that allows configuration with less system information by defining weights for different types of edges that can be adapted dynamically.

An edge $e = v_i v_j$ is of type

- *cvl* (change of voltage level), if $v_i \in TN \wedge v_j \in BB$, noted as e_{cvl} , with $E_{cvl} = \{e_{cvl} = v_i v_j \mid v_i \in TN \wedge v_j \in BB\}$,
- *be* (bus bar edge), if $v_i \in BB \wedge v_j \in GN$, noted as e_{be} , with $E_{be} = \{e_{be} = v_i v_j \mid v_i \in BB \wedge v_j \in GN\}$,
- *ne* (normal edge), if $(v_i \in GN \wedge v_j \in GN) \vee (v_i \in TN \wedge v_j \in TN)$, noted as e_{ne} , with $E_{ne} = \{e_{ne} = v_i v_j \mid (v_i \in GN \wedge v_j \in GN) \vee (v_i \in TN \wedge v_j \in TN)\}$

The time-dependent **weighting function** w assigns a weight $w_i \in [0, 1]$ to each edge from E depending on time interval and edge type:

$$w : E \times T_{pr}^{(p)} \rightarrow [0, 1] \quad (9)$$

subject to:

$$w|_{E_{cvl}}(t^{(i)}) = tw_i \quad (10)$$

$$w|_{E_{be}}(t^{(i)}) = bbw_i \quad (11)$$

$$w|_{E_{ne}}(t^{(i)}) = nw_i \quad (12)$$

denoting that the weighting function w might deliver different values (either tw_i , bbw_i or nw_i) depending on the edge type subset of E (either E_{cvl} , E_{be} or E_{ne}). With this concept, in a system with dynamic information (e.g. regarding power flow), the weighting function can be adapted dynamically to reflect properties relevant for the actual phenomena in the power grid analyzed. If no such information is given, a simple static configuration can be chosen for tw_i , bbw_i and nw_i . Especially in distribution grids, where dynamic measurement information on the grid and the units connected to the grid cannot be retrieved, a static configuration could help to approximate a reflection of grid constraints. Some details on how these weights should be chosen are given in the next section.

4.2 Neighborhood and Shortest Path

To identify the shortest path between two vertices, a neighborhood function compliant with the following requirements derived from the optimization goals for continuous scheduling (see section 2.3) is needed:

1. **Requirement 1 – Distinguish local and wide-area compensation:** Paths within the same voltage level that differ in the number of edges should be differentiated by the neighborhood function. With this requirement, local compensation of incidents (e.g. at the neighboring node) should be distinguishable from wide-area compensation. In the example given in 1, an incident occurring at node 8 should preferably get compensated at node 7 or 9.
2. **Requirement 2 – Transition of voltage levels:** Paths that have the same number of contained edges should be distinguishable if they differ regarding the voltage level profile. Thus it should be possible to prefer new schedules that compensate incidents within the same voltage level of a distribution grid or vice versa.
3. **Requirement 3 – Allow exclusion of single lines:** It should be possible to set the weight of single edges in such a way that all paths using this edge are prohibited for scheduling. Thus, congestion management with both spatial and temporal differentiation should be possible.

To reflect requirement 2 (transition of voltage levels), the following has to be valid when choosing values for the weights tw_i , bbw_i and nw_i for all time intervals $t^{(i)}$:

$$tw_i \leq bbw_i < nw_i \quad (13)$$

Choosing the same weight for tw_i and bbw_i is possible, but preferring paths within one voltage level (requirement 2) can only be done when the normal edges' weight is greater than the bus bar crossing and transformer edges' weight.

A weight of 0 annotated to an edge depicts that the line represented by this edge is prohibited for rescheduling (requirement 3), i.e. the parts of the graph that can only be reached using this edge must not be affected by rescheduling.

For the upcoming examples, the following weights are chosen for the different edge types: $tw_i = 0.7$, $bbw_i = 0.8$, $nw_i = 1.0$ for all time intervals $t^{(i)}$. Figure 2 illustrates different paths with these weights annotated to the edges.

The set of paths between v_i and v_j $Path_{(i,j)}$ is defined as follows:

$$Path_{(i,j)} = \{(v_i, v_{i+1}, \dots, v_j) \mid \exists x : e_m = v_x v_{x+1} \in E, i \leq x < j\} \quad (14)$$

A specific path is therefore an element from this set.

$$path_{(i,j),k} \in Path_{(i,j)} \quad (15)$$

To define distinct paths in the graph, paths have to be defined by naming the series of incident nodes in the

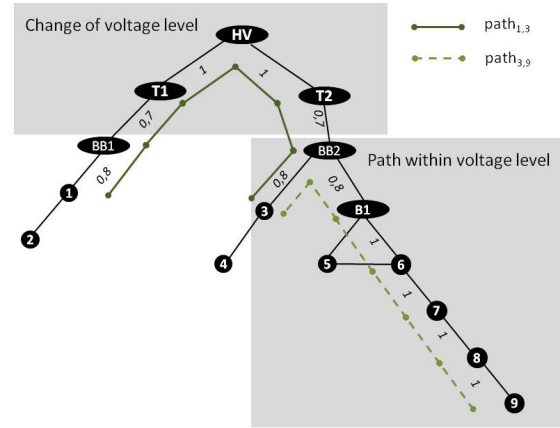

Figure 2: Exemplary paths with weights and voltage levels.

path. To simplify this for the upcoming examples, we define some paths used in the text as follows with the notation $path_{i,j}$:

$$path_{1,3}: 1 - BB1 - T1 - HV - TN - BB2 - 3$$

$$path_{3,9}: 3 - BB2 - B1 - 6 - 7 - 8 - 9$$

$$path_{B1,9}: B1 - 6 - 7 - 8 - 9$$

$$path_{6,9}: 6 - 7 - 8 - 9$$

Within definitions, we will use the notation $path_{(i,j),k}$ so that we can distinguish different paths between v_i and v_j by k where needed.

We propose the harmonic composition w_{harm} of all weights of the edges contained in the path to evaluate neighborhood as used by Kinney et al. for power grid graph analyses (Kinney et al., 2005). The harmonic composition of a set of numbers $X = \{x_1, x_2, \dots, x_n\}$ is defined as

$$w_{harm}(X) = \begin{cases} 0 & \forall X : \exists x \in X : x = 0 \\ \frac{1}{\sum_i^n \frac{1}{x_i}} & else \end{cases} \quad (16)$$

In table 1 the harmonic composition is compared to arithmetic mean and harmonic mean for example paths in the example grid. We do not compare the harmonic composition to simply summing up the weights of the edges, as requirement 3 (exclusion of single lines) cannot be fulfilled by such an approach. The above example of paths $path_{1,3}$ and $path_{3,9}$ illustrates, that requirement 2 is fulfilled using this metric: $w_{harm}(path_{1,3}) = 0.136$. The neighborhood value of $path_{3,9}$ is $w_{harm}(path_{3,9}) = 0.154$. Thus, a path within the same voltage level can be differentiated from a path crossing voltage levels as long as the weights are differentiated as shown above. This metric is defined 0 if the weight of one of the contained edges is set to 0 (requirement 3). Therefore this metric shows advantages to the arithmetic mean that

would not reflect this aspect. Further, the harmonic composition reflects the number of edges within the path (requirement 1) not reflected by arithmetic or harmonic mean: With each weight of edges set to 1.0, a path with 3 edges (e.g. $path_{6,9}$) would yield $w_{harm}(path_{6,9}) = 0.333$, whereas a path with 4 edges (e.g. $path_{B1,9}$) would yield $w_{harm}(path_{6,9}) = 0.25$.

Table 1: Metric comparison for exemplary paths.

	$path_{1,3}$	$path_{3,9}$	$path_{6,9}$	$path_{B1,9}$
# edges	6	6	3	4
arithm.	0.833	0.933	1	1
harm.	0.816	0.923	1	1
w_{harm}	0.136	0.154	0.333	0.25

The neighborhood value $neigh_{i,j}^{(i)}$ of two nodes v_i and v_j on $path_{(i,j),k}$ in time interval $t^{(i)}$ is therefore defined as follows (please note that the neighborhood definition is time-dependent, as the weighting function used is time-dependent as well):

$$neigh_{i,j}^{(i)}(path_{(i,j),k}) = w_{harm}(W_{path_{(i,j),k}}^{(i)}) \quad (17)$$

where:

$$W_{path_{(i,j),k}}^{(i)} = \{w(e_m, t^{(i)}) \mid \exists x : e_m = v_x v_{x+1} \in E, i \leq x < j\} \quad (18)$$

The shortest path $sp_{i,j}$ between nodes v_i and v_j at time interval $t^{(i)}$ is now defined as the path with the highest neighborhood value following equation 17:

$$path_{(i,j),k} = sp_{i,j}^{(i)} \quad (19)$$

subject to:

$$\forall path_{(i,j),m}, m \neq k : \quad (20)$$

$$neigh_{i,j}^{(i)}(path_{(i,j),m}) < neigh_{i,j}^{(i)}(path_{(i,j),k})$$

4.3 Adding the Grid View to Cluster Schedules

To analyze the change in power grid usage with a new cluster schedule, we first have to translate it to a node related schedule that aggregates the power behavior of units to the node they are assigned to. We define the node related schedule ns_v for each time interval as follows:

$$ns : T \rightarrow \mathbb{R}, ns_v(t^{(i)}) = \sum_{u_k \in C} e_{u_k}^{(i)} \quad (21)$$

subject to (see definition 7):

$$gn(u_k) = v \quad (22)$$

Let NS be the set of all node schedules for a cluster (i.e. nodes with units within the cluster), then the cluster node schedule cns maps a node to its node schedule:

$$cns : V \rightarrow NS, cns(v_i) = ns_{v_i} \quad (23)$$

In the example grid, a maximum of one unit is assigned to each node for the sake of conceptual clarity. Unit and node can thus be referred to with the same number in the explaining text. Therefore, the energy entries in the cluster schedules are equivalent to the cluster node schedule throughout the rest of this paper.

5 USING GRID RELATED CLUSTER SCHEDULE RESEMBLANCE FOR ENERGY RESCHEDULING

With the grid characteristics of a cluster schedule as defined in the last section, an optimized rescheduling can reflect grid characteristics besides other optimization goals as costs and robustness. To implement this, we define grid-related resemblance of cluster schedules and give an example of how this can be used to choose a new cluster schedule from a set of possible rescheduling options.

5.1 Rescheduling and Comparison of Grid Characteristics

We define two cluster schedules to be grid-related identical, if their cluster node schedules are identical, i.e. rescheduling only affects units assigned to the same grid node.

The grid-related cluster schedule resemblance $gr(cs^*)$ of a new cluster schedule cs^* with the original cluster schedule cs is defined as follows (with v_{inc} as node where at least one unit affected by an incident is connected and $sp_{inc,k}$ as shortest path between v_{inc} and v_k as defined in definitions 19 and 20):

$$gr(cs^*) = \sum_{t^{(i)} \in T_{pr}^{(p)}} \sum_{v_k \in G} \frac{\beta_i \cdot w_{inc,k}^{(i)}}{\sum \beta_i} \quad (24)$$

where:

$$w_{inc,k}^{(i)} = neigh_{inc,k}^{(i)}(sp_{inc,k}^{(i)}) \cdot |ns_{v_k}^{(i)} - ns_{v_k}^{*(i)}| \quad (25)$$

The dynamic weighting factor β_i can be used to reflect time intervals within a day where schedule deviations are considered more critical. For the rest of

this paper β_i is set to 1 for all time intervals and thus has no effect. The evaluation on the effect of this factor is subject to future work.

5.2 Example: Choosing a New Cluster Schedule Using Grid-Related Plan Resemblance

For the grid example given above, an original cluster schedule was chosen for the cluster $C = \{u1, u2, u3, u6, u7, u8\}$ for one time interval. For this interval, an incident occurs at unit 2 decreasing the original power production from 4 to 1. In table 2, an excerpt of possible new cluster schedules is given. All of these possible new cluster schedules fulfill the requirement, that power delivery sums up to 25. In figure 3 and figure 4 the units compensating the incident when using schedules 1 or 2 are marked to illustrate the topological dimension of the schedule change. Please note, that the energy related change in the schedule can only be deduced from table 2. Both dimensions are used for grid related cluster schedule resemblance.

Table 2: Original and potential new cluster schedules.

	orig	sched1	sched2	sched3	sched4
u2	4	1	1	1	1
u1	1	4	3	3	3
u3	4	4	1	5	4
u6	6	6	6	6	6
u7	5	5	8	5	5
u8	5	5	6	5	6
Σ	25	25	25	25	25

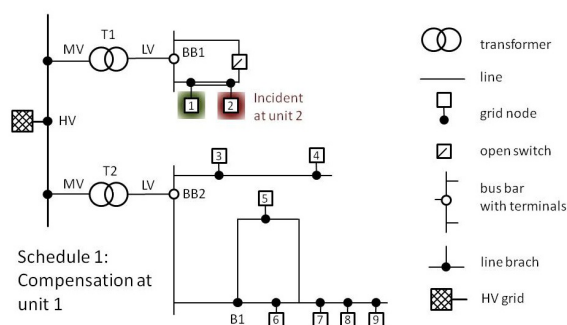

Figure 3: Following schedule 1 a directly neighbored unit is used to compensate the incident at unit 2.

The grid related cluster schedule resemblance as defined in equation 24 is listed in table 3. Schedule 1 compensates the incident at unit 2 occurring at node

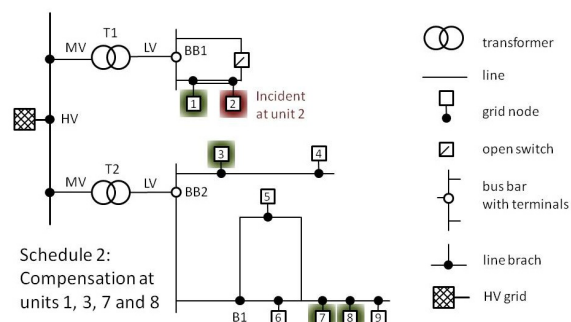

Figure 4: With schedule 2 the incident at unit 2 would get compensated by several units located even in a separate LV grid.

Table 3: Characteristics of new cluster schedules.

	sched1	sched2	sched3	sched4
# reconf.	1	4	2	2
$gr(cs^*)$	0.6	0.533	0.421	0.416

2 at the directly neighbored node 1 using unit 1 without crossing more than one edge and within the same voltage level (see figure 3). This plan has the highest grid-related cluster schedule resemblance. Schedule 2 (see figure 4) has the highest number of reconfigurations, but grid resemblance is high nevertheless. Schedules 3 and 4 come with a small number of reconfigurations but compensate with stark changes at the most distant grid nodes. It can be seen, that grid related cluster schedule resemblance decouples the amount of reconfigurations needed for compensation (as a cost-relevant aspect) and grid characteristics of a plan.

6 CONCLUSIONS AND FUTURE WORK

In this paper we propose grid-related cluster schedule resemblance as a new metric to compare schedules for clusters of distributed energy generators and consumers regarding their grid usage profile changes. It was shown that this metric can decouple the amount of reconfigurations needed for compensation (as a cost-relevant aspect) and grid characteristics of a plan. Therefore grid related cluster schedule resemblance can be used as a separate optimization target in the multi-criteria optimization problem of energy cluster rescheduling that deals with costs and other targets as well.

In future work we will compare the results from this metric with conventional load flow calculations to evaluate, if the schedules chosen using the metric lead

to less critical grid operation regarding operational constraints of transformers and lines. If the metric developed in this work thus shows to be appropriate as a means to reflect grid constraints in rescheduling distributed energy units, we will apply this approach to evaluate multi-dimensional schedules e.g. for rescheduling of clusters active on day-ahead markets combined with cost and robustness. We will integrate this optimization in a distributed constraint optimization problem to adapt schedules to unforeseen incidents on distributed power generation and usage.

ACKNOWLEDGEMENTS

The Lower Saxony research network ‘Smart Nord’ acknowledges the support of the Lower Saxony Ministry of Science and Culture through the “Niedersächsisches Vorab” grant programme (grant ZN 2764).

Furthermore, we thank Sebastian Lehnhoff and the anonymous reviewers for helpful comments to improve this paper.

REFERENCES

- Abarrategui, O., Marti, J., and Gonzalez, A. (2009). Constructing the Active European Power Grid. In *Proceedings of WCPEE09*, pages 1–4, Cairo.
- Albert, R., Albert, I., and Nakarado, G. L. (2004). Structural Vulnerability of the North American Power Grid. *Physical Review E*, 69(025103(R)):1–10.
- Albert, R., Jeong, H., and Barabasi, A. (2000). Error and attack tolerance of complex networks. *Nature*, 406(6794):378–82.
- Barabási, A. and Albert, R. (1999). Emergence of Scaling in Random Networks. *Science*, 286(5439):509–512.
- Bitsch, R., Feldmann, W., and Aumayr, G. (2002). Virtuelle Kraftwerke - Einbindung dezentraler Energieerzeugungsanlagen. *etz*, 9.
- Blank, M., Gerwinn, S., Krause, O., and Lehnhoff, S. (2011). Support vector machines for an efficient representation of voltage band constraints. *2011 2nd IEEE PES International Conference and Exhibition on Innovative Smart Grid Technologies*, pages 1–8.
- Bundesnetzagentur (2012). Amtsblatt 21/2012 der Bundesnetzagentur, Beschluss BK6-12-024.
- Chopade, P. and Bikdash, M. (2011). Critical infrastructure interdependency modeling: Using graph models to assess the vulnerability of smart power grid and SCADA networks. *2011 8th International Conference & Expo on Emerging Technologies for a Smarter World*, pages 1–6.
- Dimeas, A. L. and Hatziargyriou, N. (2007). Agent based control of Virtual Power Plants. In *International Conference on Intelligent System Applications to Power Systems*, pages 1–6, Toki Messe, Niigata.
- Gandor, M., Blank, M., and Lehnhoff, S. (2012). Reconfiguration Strategies for Electrical Devices for Operation within Feasibility Margins. In *VDE-Kongress 2012 Smart Grid*, Stuttgart. VDE Verlag GmbH.
- Gwisdorf, B., Stepanescu, S., and Rehtanz, C. (2010). Effects of Demand Side Management on the Planning and Operation of Distribution Grids. In *Innovative Smart Grid Technologies Conference Europe (ISGT Europe), 2010 IEEE PES*.
- Handschin, E., Rehtanz, C., Wedde, H. F., Krause, O., and Lehnhoff, S. (2008). On-line stable state determination in decentralized power grid management. In *Proceedings of the 16th Power Systems Computation Conference (PSCC'08)*, pages 07–14, Glasgow, Scotland, UK.
- Hines, P., Blumsack, S., Sanchez, E. C., and Barrows, C. (2010). The Topological and Electrical Structure of Power Grids. *2010 43rd Hawaii International Conference on System Sciences*, pages 1–10.
- Holmgren, A. J. (2006). Using graph models to analyze the vulnerability of electric power networks. *Risk analysis : an official publication of the Society for Risk Analysis*, 26(4):955–69.
- Jansen, J. C., van der Welle, A., and Nieuwenhout, F. (2008). The virtual power plant concept from an economic perspective: updated final report. Technical Report 0.
- Khattabi, M., Hübner, C., Kießling, A., and Braun, M. (2012). Distribution grid automation as the basis for the smart energy system of the future. In VDE, editor, *VDE-Kongress 2012 Smart Grid*, Stuttgart. VDE Verlag.
- Kinney, R., Crucitti, P., Albert, R., and Latora, V. (2005). Modeling cascading failures in the North American power grid. *The European Physical Journal B*, 46(1):101–107.
- Kok, K. (2010). Multi-Agent Coordination in the Electricity Grid, from Concept towards Market Introduction. In *Ninth Conference on Autonomous Agents and Multiagent Systems AAMAS 2010*, pages 1681–1688, Toronto, Canada.
- Kok, K., Warmer, C., Kamphuis, R., Mellstrand, P., and Gustavsson, R. (2005). Distributed Control in the Electricity Infrastructure. In *Proceedings of the International Conference on Future Power Systems, 2005*.
- Krause, O. and Lehnhoff, S. (2012). Generalized Static-State Estimation. In *22nd Australasian Universities Power Engineering Conference (AUPEC)*.
- Neusel-Lange, N., Oerter, C., and Zdrallek, M. (2012). State Identification and Automatic Control of Smart Low Voltage Grids. In *Proceedings of the 3rd IEEE-PES-Conference "Innovative Smart Grid Technologies" Europe 2012*, pages 1–6, Berlin, Germany.
- Nguyen, P. H., Kling, W. L., and Myrzik, J. M. A. (2010). An application of the successive shortest path algorithm to manage power in multi-agent system based

- active networks. *European Transactions on Electrical Power*, 20(8):1138–1152.
- Nguyen, P. H., Kling, W. L., and Ribeiro, P. F. (2011). Agent-based power routing in Active Distribution Networks. *2011 2nd IEEE PES International Conference and Exhibition on Innovative Smart Grid Technologies*, pages 1–6.
- Nieße, A., Lehnhoff, S., Tröschel, M., UsLAR, M., Wissing, C., Appelrath, H.-J., and Sonnenschein, M. (2012). Market-based self-organized provision of active power and ancillary services: An agent-based approach for Smart Distribution Grids. In *Complexity in Engineering (COMPENG), 2012*, Aachen.
- Ramchurn, S. D., Vytelingum, P., Rogers, A., and Jennings, N. R. (2012). Putting the Smarts into the Smart Grid : a Grand challenge for artificial intelligence. *Communications of the ACM*, 55(4):86–97.
- Schneider, C. M., Ara, N. A. M., Havlin, S., and Herrmann, H. J. (2011). Towards designing robust coupled networks. pages 1–7.
- VDE (2011). VDE-AR-N 4105: Erzeugungsanlagen am Niederspannungsnetz - Technische Mindestanforderungen für Anschluss und Parallelbetrieb von Erzeugungsanlagen am Niederspannungsnetz.
- Wang, Y., Zhao, J., Zhang, F., and Lei, B. (2012). Study on structural vulnerabilities of power grids based on the electrical distance. *IEEE PES Innovative Smart Grid Technologies*, pages 1–5.